

READY TO EXCEED.



TMT TAPPING
MEASURING
TECHNOLOGY

MEASURING TECHNOLOGY

FOR BLAST FURNACE PROCESS CONTROL

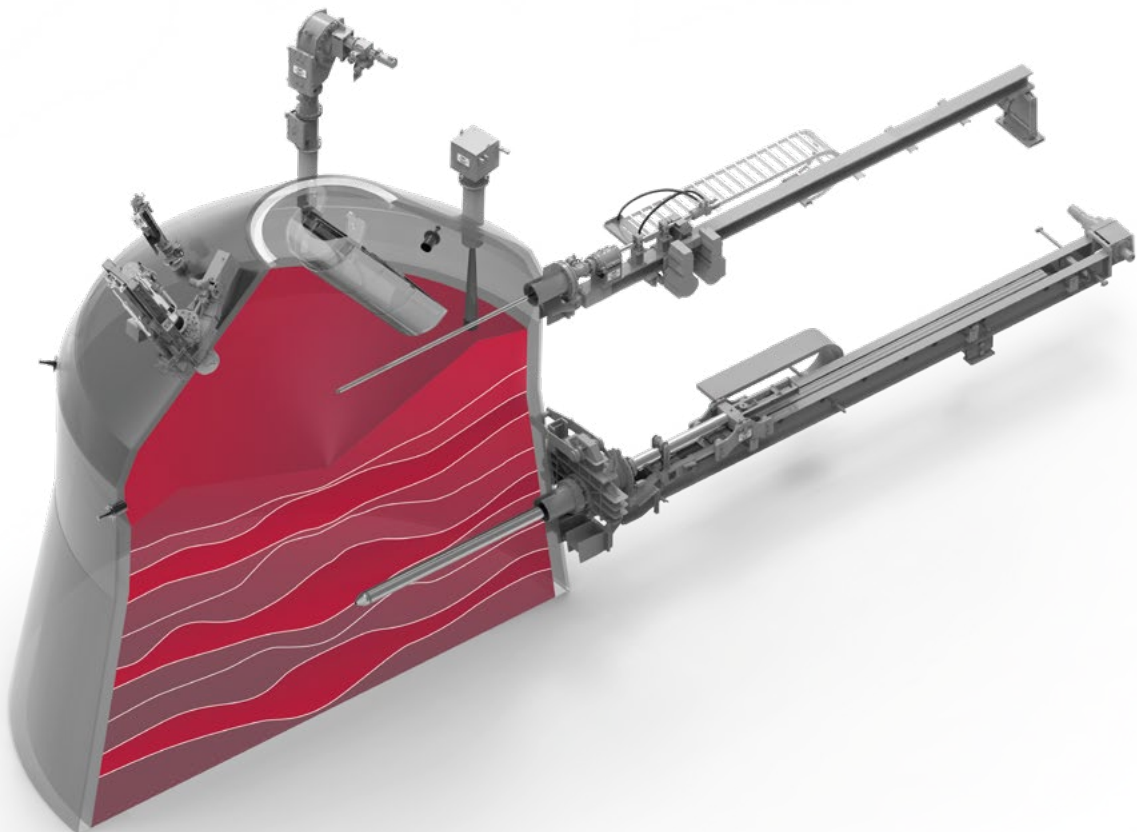

MAKE YOUR BLAST FURNACE PROCESS TRANSPARENT

3D TOPSCAN™

/ PROCESS FEEDBACK

- ▶ Live 3D burden surface monitoring
- ▶ Detection of all asymmetries
- ▶ 3D layer model
- ▶ Areal burden descent speed

/ YOUR BENEFITS

- ▶ No parts penetrating into top cone area avoids interference with burden charging
- ▶ Fast and continuous (24/7) measurement
- ▶ Highest resolution
- ▶ Maintenance possible with furnace on blast
- ▶ Better understanding of process leading to coke savings
- ▶ Early detection of anomalies avoiding costly process disturbance

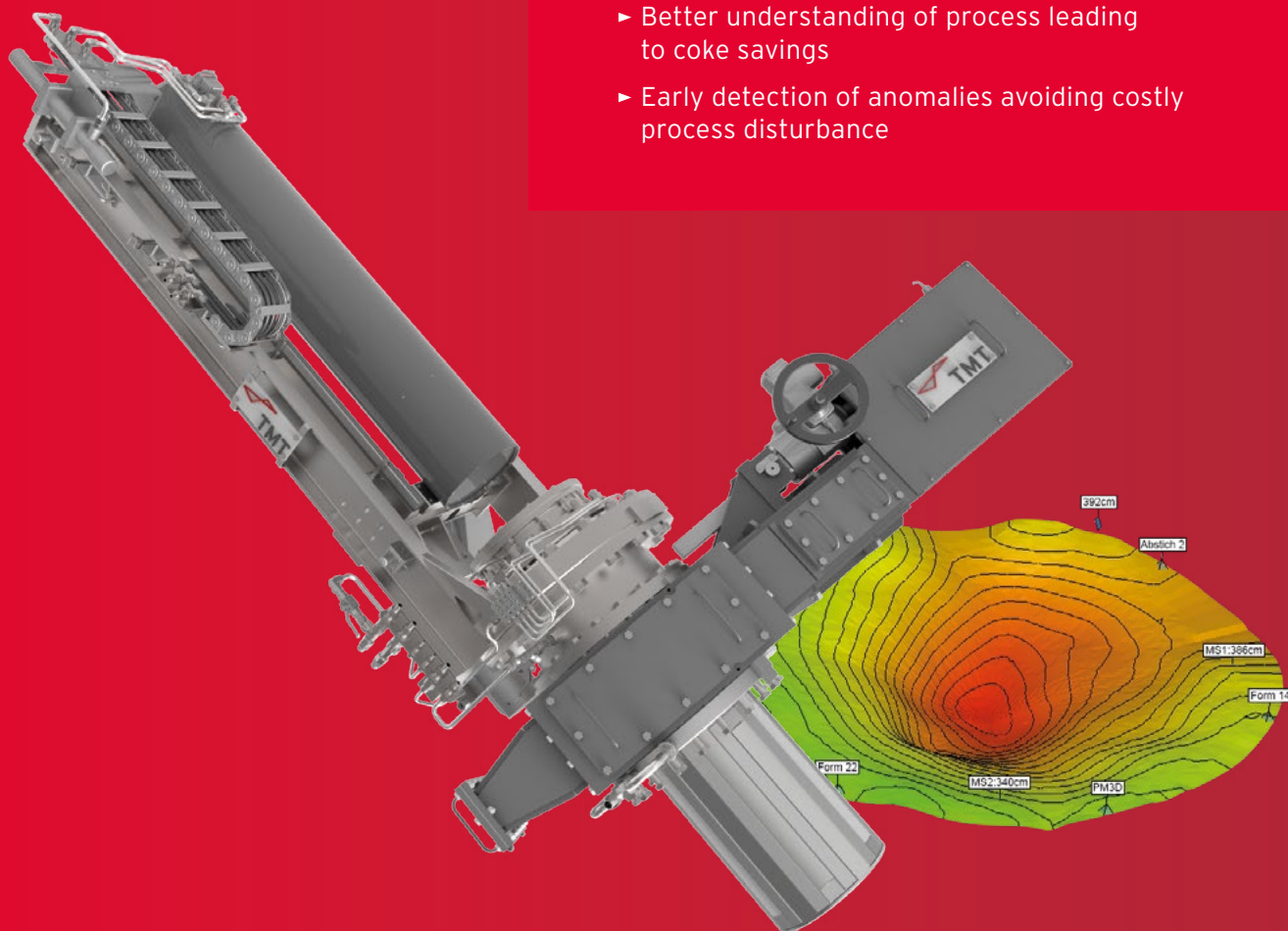

TMT SOMA™

/ PROCESS FEEDBACK

- ▶ 2D gas temperature measurement covering the whole burden surface
- ▶ Position of gas channel
- ▶ Balance between wall and centre flux

/ YOUR BENEFITS

- ▶ Improved process feedback through visualization of 2D gas temperature distribution in the entire top cone for process optimization and reduction of coke consumption
- ▶ Trending of gas channel positions for immediate process corrections
- ▶ Detection of abnormal process behavior
- ▶ Longer lifetime and lower maintenance requirements than conventional above burden probes

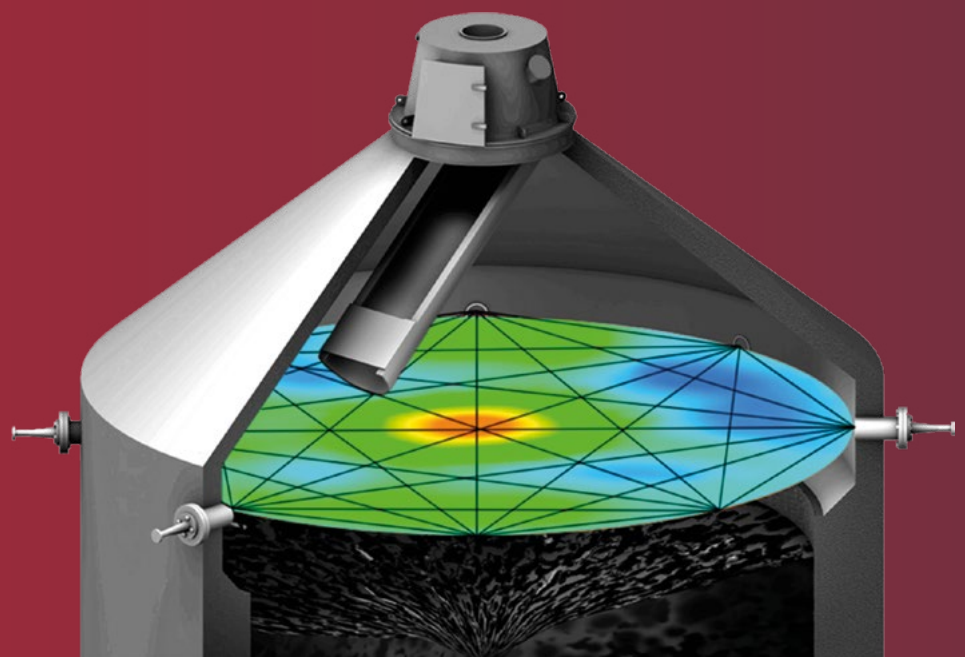

CHARGING DATA

PROBES FOR LEVEL MEASUREMENT
PROBES FOR CHARGING CONTROL



Continuous stockline level control

Combinations of mechanical- and radar stockline indicators allow reliable measurement of the burden level and its descent speed under all operating conditions and during blow-downs.

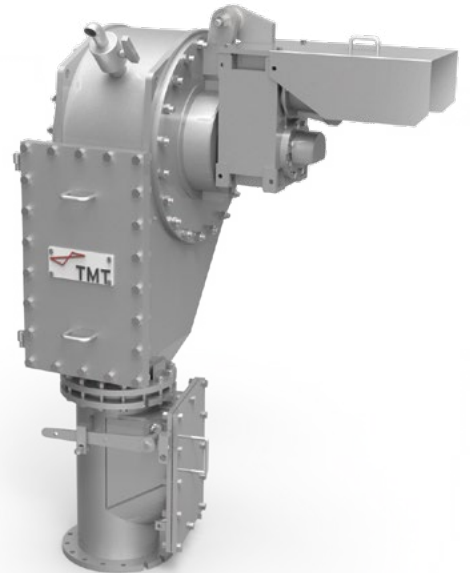

RADAR STOCKLINE DETECTORS

/ PROCESS FEEDBACK

- ▶ Continuous measuring of burden level and possible calculation of descent speed
- ▶ Measuring range: up to -32 m

MECHANICAL STOCKLINE DETECTOR

/ PROCESS FEEDBACK

- ▶ Measurement of burden level and burden descent rate
- ▶ Accurate measurements up to -24 m

/ YOUR BENEFITS

Continuous and reliable measurement of stockline level to control BF charging

Protected and cooled radar electronics ensure low-maintenance requirements and long service life

/ YOUR BENEFITS

Proven reliability

Low maintenance

Measurements possible under all BF conditions

Stable and efficient operation

Tools continuously detecting the true charging profile or detecting changes in the falling curve of the burden material as consequence of chute wear or changing raw material properties enable the operators to adjust the charging and save costs.

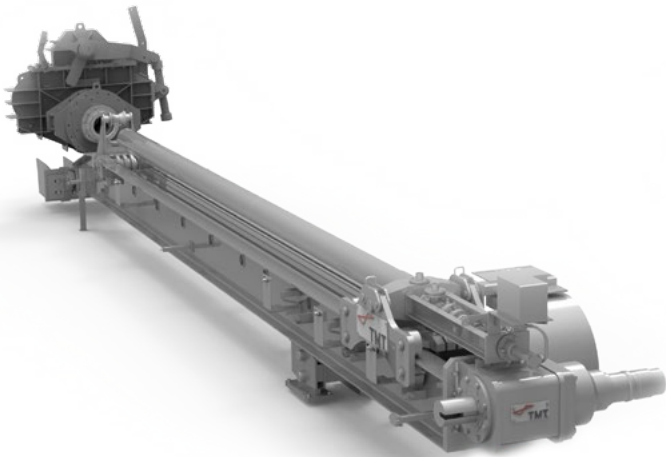

SCANNING PROBE

/ PROCESS FEEDBACK

- ▶ Detection of the burden distribution
- ▶ Visualization of the burden layers

/ YOUR BENEFITS

Evaluation of burden distribution and its influence on the blast furnace process

Understand and optimize the blast furnace process together with gas and temperature measurements

IMPACT PROBE

/ PROCESS FEEDBACK

- ▶ Detects material falling curve changes

/ YOUR BENEFITS

Enabling the operator to adjust the chute angle

Reduce production costs by improving the accuracy of the charging

Can be integrated into existing 2D-profilemeters or installed as separate probe

PROCESS DATA

PROBES FOR MEASUREMENTS ABOVE AND BELOW THE BURDEN

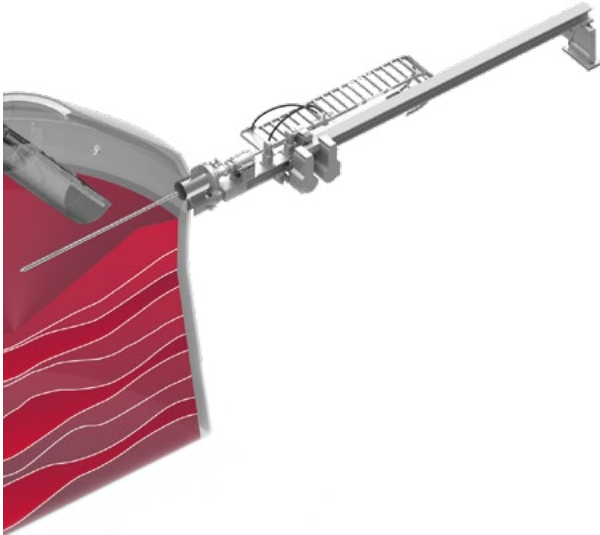

FIXED & MOVABLE ABOVE BURDEN PROBES

/ PROCESS FEEDBACK

- ▶ Gas temperature above the burden
- ▶ Optional: chemical gas composition in combination with a TMT gas-conditioner and analyzer

/ OPTIONAL

- ▶ Fully automated gas sampling and analysing sequence for ease of operation
- ▶ Water-injection into BF-centre to cool down excessive top gas temperatures

/ YOUR BENEFITS

Optimize the BF-process by allowing to adjust the burden distribution

Temporary protrusion into the BF to avoid disturbance of charging

Best suited for combination with TMT-SOMA®

Above and below the burden

The temperature distribution and the chemical composition of the gas are reliable indicators for the efficiency of the reduction process. Both are determining factors for operators, seeking to reduce the fuel-rate and to cut the production costs.

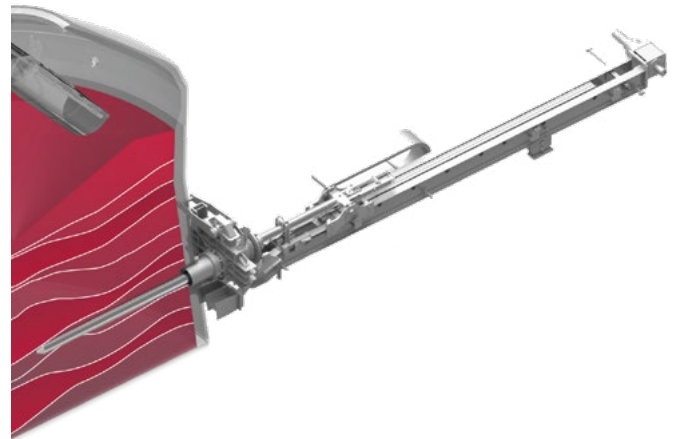

IN-BURDEN PROBE

/ PROCESS FEEDBACK

- ▶ Gas temperature and gas composition (CO, CO₂ and H₂; N₂ calculated)
- ▶ Measurements are taken below stockline level at multiple points on a BF radius

/ YOUR BENEFITS

Adapting the charging matrix to reduce the coke rate

Visualisation of CO, CO₂, H₂, N₂ calculated, ETA-CO (gas efficiency) eases the interpretation of the measured data

Rigid water-cooled design for long service life

BF-CAMERAS

Visualize your top-cone

Based on infrared emissions the BF-camera generates a real time video of the interior of a BF.

With improved dust penetration capabilities and increased temperature ranges, BF-cameras have become an important tool to visually evaluate the interior of the BF top cone.

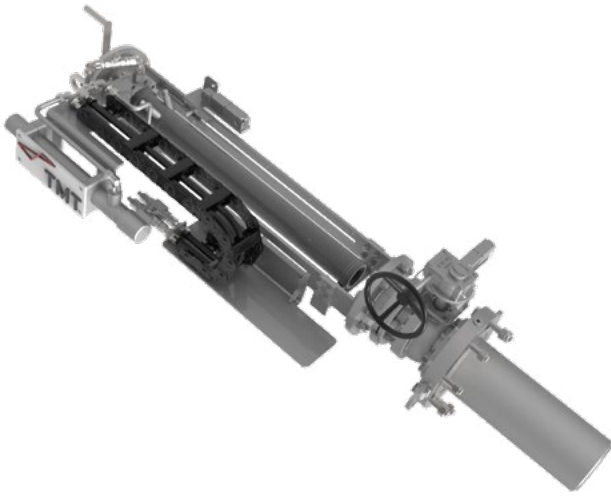

FURNOSCOPE™

/ PROCESS FEEDBACK

- ▶ Visual validation of the BF-process, the BF top cone and the installed equipment

/ YOUR BENEFITS

Latest camera sensor allow for significantly improved dust penetration as well as a visualisation at lower BF-temperatures

On blast maintenance possible

SPECIAL PROBES

Refine Your Processes

A wide variety of special probes can provide further measurement data that help the BF-operators to either fine-tune the reduction process in the furnace or support them to refine the processes in the casthouse.

/ LIQUID LEVEL MEASUREMENT

- ▶ Evaluation of the liquid level inside the BF hearth for advanced tapping management

/ TORPEDO LEVEL RADAR PROBES

- ▶ Continuous supervision of torpedo filling level

/ HIGH ACCURACY TOP GAS ANALYSER

- ▶ Continuous BF-gas analysis at high accuracy for increase of process efficiency and reduction of fuel rate

/ MULTI POINT VERTICAL PROBE

- ▶ Measurement of complete blast furnace gas and temperature profiles at different heights
- ▶ For burden analyses across BF section

VARIOUS OTHER PROBES

**NO MATTER WHERE,
SUPPORT IS JUST
AROUND THE CORNER.
WORLDWIDE.**

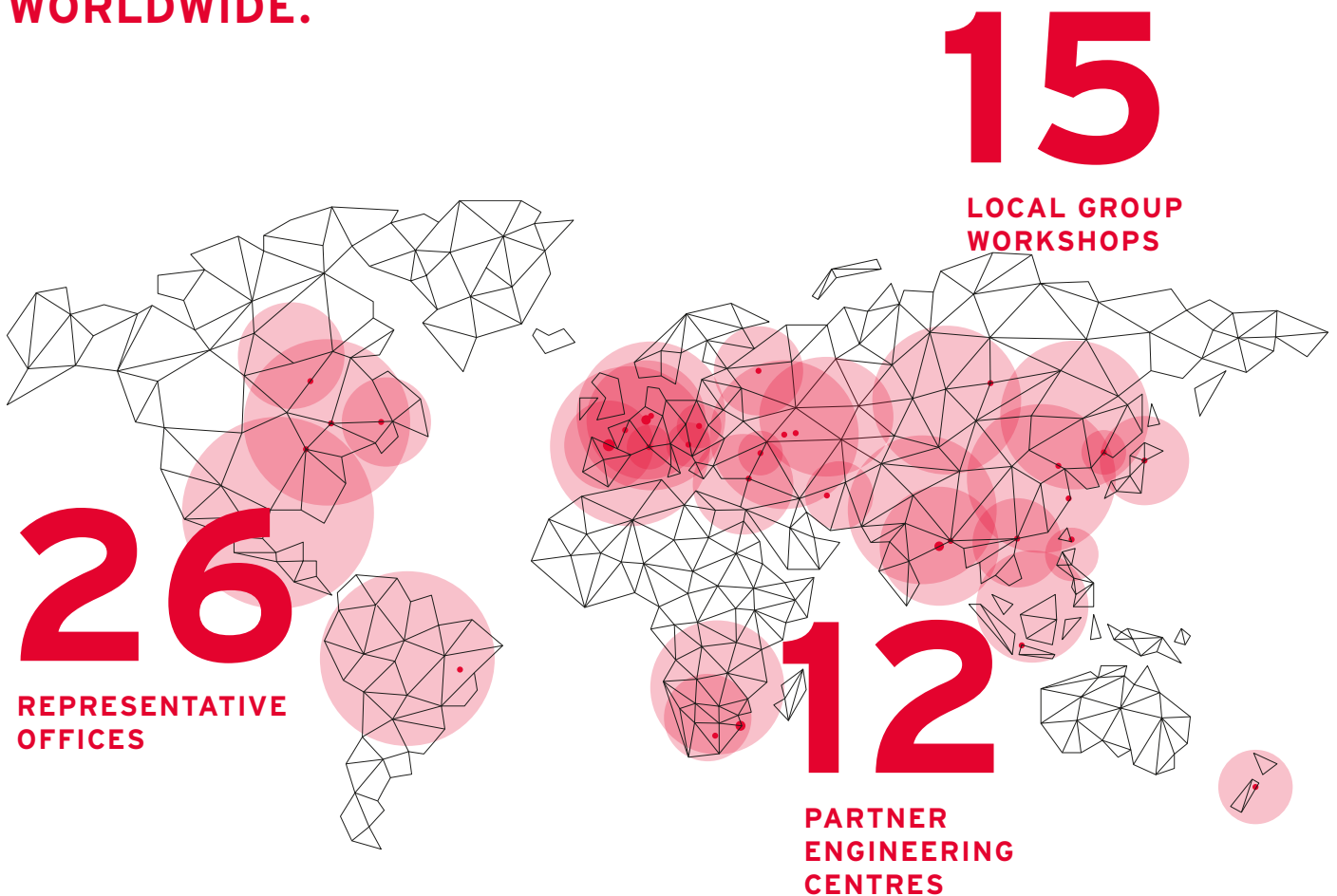

Maximum equipment availability

With TMT you have local support around the world. OEM subsidiaries and workshops spread around the globe are ready to assist you throughout the lifetime of the equipment.

/ SERVICES

- ▶ Comprehensive refurbishments to extend the lifetime of your equipment
- ▶ Tailor made technology upgrades to boost the performance of existing equipment and to increase the safety level
- ▶ Site surveys and preventive maintenance to ensure availability of the equipment
- ▶ Supply of OEM spare parts and consumables to ensure reliable performance